

B2961B and B2962B

6.5 Digit Low Noise Power Source

1 ch/2 ch, 210 V, 3 A DC/10.5 A Pulse, 31.8W,
100 nV/10 fA Resolution



Table of Contents

| | |
|--|----|
| Impressive 6.5 Digit 100 nV/10 fA Resolution, 10 μ Vrms Ultra Low Noise and Innovative Source Functions Accelerate Your Research and Development | 3 |
| Key Features and Benefits..... | 4 |
| Superior Resolution and Wide Bipolar Ranges Meet your Most Challenging Test and Evaluation Needs | 5 |
| Best-in-Class Noise Performance (10 μ Vrms) Unlocks the True Characteristics of Your Devices and Samples | 7 |
| Intuitive Front-Panel GUI and Wide 4.3" Color LCD Maximize Test and Debug Efficiency | 10 |
| GUI Based Intuitive Front Panel Design with Rich Standard Interfaces for Your Bench-Top Needs | 11 |
| Flexible Source Functions Beyond a DC Instrument Remove Your Test Restrictions | 12 |
| Programmable Output Resistance and DC Voltage/Current Output Emulation Capabilities Solve Real-World Measurement Challenges | 14 |
| Multiple Communication Methods and Software Provide Flexible and Convenient Remote Control Options | 16 |
| Key Specifications..... | 18 |
| Specifications | 19 |
| Source Supplemental Characteristics | 21 |
| Furnished Accessories..... | 36 |
| Ordering Information | 36 |

Impressive 6.5 Digit 100 nV/10 fA Resolution, 10 μ Vrms Ultra Low Noise and Innovative Source Functions Accelerate Your Research and Development

Revolutionary power supply/source meets both existing and future test needs

Power supplies/sources are essential instruments for test and evaluation across the electronics industry. The on-going industry trends of reduced power consumption and faster communication data rates increasingly require power sources that can support lower levels of current and voltage. These requirements mandate that power supplies/sources meet ever higher levels of performance.

The Keysight B2961B/B2962B 6.5 Digit Low Noise Power Source is a new bench-top power supply/source with revolutionary capabilities and functions not previously available. Its unique features include bipolar current sourcing and sinking, a programmable output resistance feature, and a time-domain waveform viewer supported in the graphical user interface (GUI).

You can choose between 1-channel (B2961B) and 2-channel (B2962B) models, allowing you to select the exact amount of bench-top power source performance to meet your testing needs.

- Best-in-class 6.5 digit resolution (100 nV/10 fA minimum resolutions)
- Wide bipolar (4-quadrant) voltage/current ranges (210 V/3 A DC, 10.5 A Pulse)
- Ultra low noise filter (10 μ Vrms, 1 nV/ $\sqrt{\text{Hz}}$ at 10 kHz)
- Intuitive graphical user interface with wide 4.3" color LCD
- Convenient 4.5 digit voltage/current monitor
- Time domain waveform viewer for quick check and debug
- Precision 1 mHz –10 kHz arbitrary waveform generation capability
- Flexible programmable output resistance function

In addition to these innovative bench-top power supply/source features, the B2961B/B2962B can be controlled remotely using Keysight PC-based BenchVue, Quick I/V Measurement Software or through any LXI compliant web browser. These capabilities simplify the task of incorporating measurement data and graphs into reports and presentations.

The superior performance and innovative functions of the B2961B/B2962B cover a broad range of test applications.

Key Features and Benefits

| Feature | Benefit |
|--|---|
| Best-in-class resolution and wide bipolar range <ul style="list-style-type: none"> • 6.5 digit (100 nV/10 fA resolution) • 210 V and 3 A (DC)/10.5 A (pulsed) ranges • 4-quadrant operation | Very precise test and evaluation can be performed within a wide 4-quadrant voltage and current range. |
| External ultra low noise filter (option) <ul style="list-style-type: none"> • 10 μVrms (10 Hz – 20 MHz) • 1 nVrms/$\sqrt{\text{Hz}}$ at 10 kHz | Reveal more of the true characteristics of your noise-sensitive devices and samples than ever before. |
| Intuitive GUI implemented on 4.3" color LCD <ul style="list-style-type: none"> • 4.5 digit voltage/current monitor • Time domain waveform viewer | Improved test and debug efficiency without the need for a PC. |
| Precision 1 MHz –10 kHz arbitrary waveform generation capability <ul style="list-style-type: none"> • Voltage and current waveform generation up to 210 V/3 A • Support for six built-in waveforms and a user-defined arbitrary waveform | Goes beyond simple DC measurement and allows you to perform complex and more sophisticated testing of your devices and samples. |
| Versatile programmable output resistance function <ul style="list-style-type: none"> • Constant mode • Voltage/current emulation mode | Enables you to simulate a wide variety of devices and sample types. |

A wide variety of B2961B/B2962B applications

To reduce power consumption battery-powered devices continue to reduce their supply voltage levels, which requires ever more precise power sources to accurately characterize device behavior. Noise performance requirements also continue to become more stringent in application areas such as mobile communications due to higher data rates and faster clock frequencies. These technology trends make the testing of advanced products increasingly difficult due to their extreme sensitivity to noise and other external disturbances.

As a result, power supplies/sources with more precision, better noise performance and more versatile sourcing functions are now required. The B2961B/B2962B meet these requirements, and they can be used for a wide variety of applications that permit you to perform critical tests and evaluations that have not been previously possible.

In addition, the B2961B/B2962B's superior performance and innovative functions make these instruments ideal companion power supplies/sources for use with other instruments such as network analyzers, spectrum analyzers, digital multimeters and nano-voltmeters.

Application examples

- A/D and D/A converters
- High precision analog IC and circuitry
- RFICs and circuitry
- Medical applications
- Cable/wire harnesses evaluation
- Voltage controlled oscillators (VCOs)
- Sensor devices and transducers
- Solar cells and the interface circuitry
- Electrochemical applications
- Research and education
- Crystal oscillators
- Current source for small voltage measurement
- Battery management
- Advanced materials evaluation

Superior Resolution and Wide Bipolar Ranges Meet your Most Challenging Test and Evaluation Needs

6.5 digit resolution enables precise analog-to-digital converter evaluation

evaluation. For an 8-bit ADC, a 1 V (peak to peak) signal would have a minimum step voltage of 3.9 mV. In this case a power source with 4.5 digit resolution is sufficient to use for the DC input voltage. However, for an ADC with 14-bits or more, 4.5 digit resolution is not enough. In this case the B2961B/B2962B's best-in-class 6.5-digit sourcing resolution is required in order to properly evaluate the ADC circuit.

| ADC Resolution | Steps | Min Step Voltage | Conventional power supply resolution (4.5 digit/ Min 100 μ V) | B2961B/B2962B resolution (6.5 digit/ Min 1 μ V) |
|----------------|--------|------------------|---|---|
| 8-bit | 256 | 3.9 mV | √ | √ |
| 10-bit | 1,024 | 1.0 mV | √ | √ |
| 12-bit | 4,096 | 244 μ V | √ | √ |
| 14-bit | 16,384 | 61 μ V | | √ |
| 16-bit | 65,536 | 15 μ V | | √ |

Figure 1. Resolution comparison: ADC with 1 V_{pp} (Full Scale)

Wide bipolar range (100 nV to 210 V, 10 fA to 10.5 A) permits characterization of many types of devices and samples

The wide bipolar (four-quadrant) voltage and current ranges of the B2961B/B2962B are capable of supporting both current and future testing needs. In addition, since they support both very small and very large current and voltage signal levels the B2961B/B2962B can often replace several other bench-top instruments. As shown in Figure 2, you can program any voltage and current value within the B2961B/B2962B's wide output range without worrying about any zero-crossing glitches.

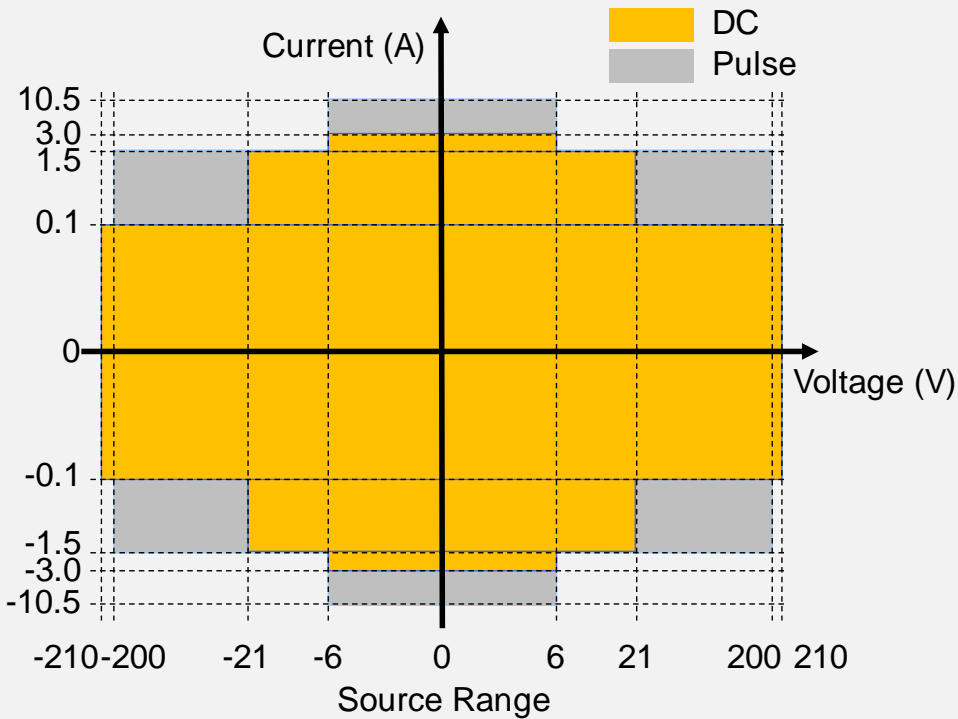

Figure 2. Wide bipolar voltage and current ranges (4-quadrant operation)

Fast settling time increases your test efficiency

Unlike most conventional power supplies/sources, the B2961B/B2962B can quickly settle to their final value with 6.5 digit resolution throughout their entire output ranges. This reduces test times and improves measurement efficiency, especially when making multiple tests in sequence. See Figure 3.

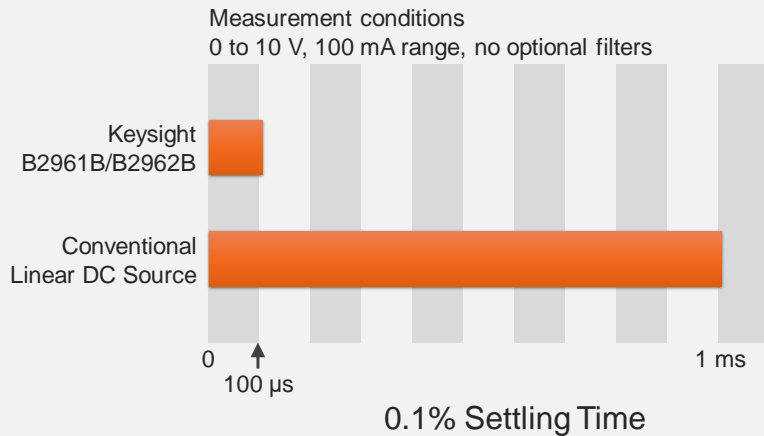

Figure 3. Fast settling time than conventional DC sources

Best-in-Class Noise Performance (10 μ Vrms) Unlocks the True Characteristics of Your Devices and Samples

Three optional filters available for different test needs

For applications requiring ultra-low noise performance, the B2961B/B2962B supports three external filter options. This provides you with the flexibility to select the noise filter price/performance point that best meets your needs. The low noise filter (LNF) provides the same level of RMS noise as linear regulator-based power supplies and sources, while the high current ultra low noise filter (HC-ULNF) and the ultra low noise filter (ULNF) reduces noise to an impressive 10 μ Vrms. See Figure 4.



Figure 4. Optional external noise filters can meet your most stringent noise requirements

HC-ULNF and ULNF provide unprecedented low-noise performance (10 μ Vrms and 1 nVrms/ $\sqrt{\text{Hz}}$ at 10 kHz) in a low-cost bench-top instrument

As shown in Figure 5 both HC-ULNF and ULNF reduce the voltage noise of the B2961B/B2962B to 10 μ Vrms in the frequency range of 10 Hz – 20 MHz. The differences between HC-ULNF and ULNF are voltage and current coverage. HC-ULNF allow it to source up to 21 V and 500 mA, and ULNF allowing up to 42 V and 105 mA. This outstanding low noise performance can be used to evaluate noise-sensitive devices and circuits such as ADC/DAC as well as many other types of analog and RF ICs. In addition, see Figure 6. the HC-ULNF and ULNF minimizes the noise density to 1 nVrms/ $\sqrt{\text{Hz}}$ at 10 kHz, which is required for the phase noise evaluation of oscillator circuits such as VCOs, crystal oscillators, etc. There are two user-selectable output impedance settings, 2-wire (50 Ω) and 4-wire (low impedance close to zero), to provide optimal flexibility when characterizing your devices and samples.

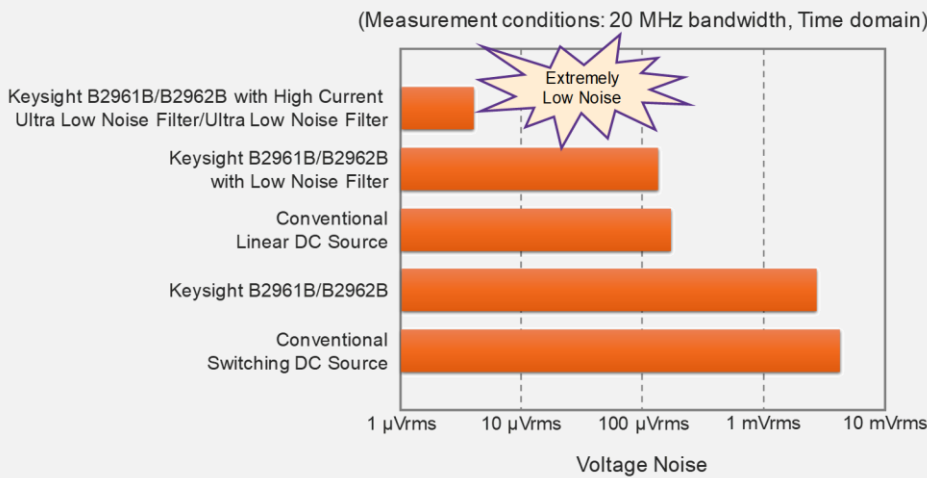

Figure 5. HC-ULNF and ULNF dramatically reduce output noise

LNF supports full 210 V and 3 A bipolar output range

The LNF supports the B2961B/B2962B's wide bipolar voltage and current ranges (up to 210 V/3 A) while providing noise levels comparable to those of linear power supplies. In addition, when using the LNF you can still make 4-wire (Kelvin) measurements to eliminate residual cable resistance effects. For applications requiring a moderate level of low-noise performance, the LNF provides a cost-effective means to achieve low-noise sourcing capability for a modest price.

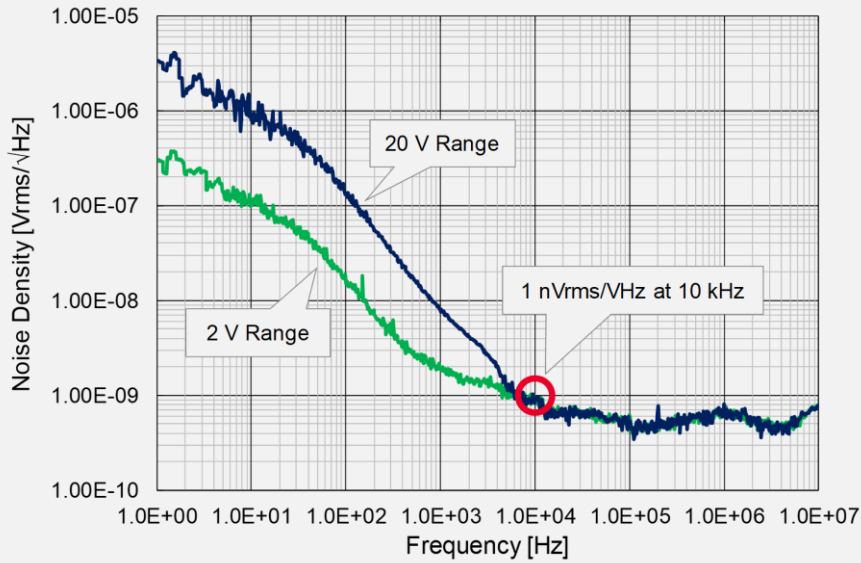

Figure 6. HC-ULNF and ULNF provide excellent noise density performance

Intuitive Front-Panel GUI and Wide 4.3" Color LCD Maximize Test and Debug Efficiency

Many power supplies and sources only possess a numerical display or a very basic dot matrix display, which are only effective at showing DC values. In contrast, the B2961B/B2962B has an easy-to-use front panel GUI and a wide 4.3" color LCD. These make it easy to set up sourcing parameters and to display complex current and voltage waveforms. For added convenience, the B2961B/B2962B provides multiple viewing modes: single view, dual view (B2962B only) and graph view. These capabilities not only increase test and evaluation efficiency, but they also make the instrument easy to use without the need to struggle through paper manuals. See Figure 7.

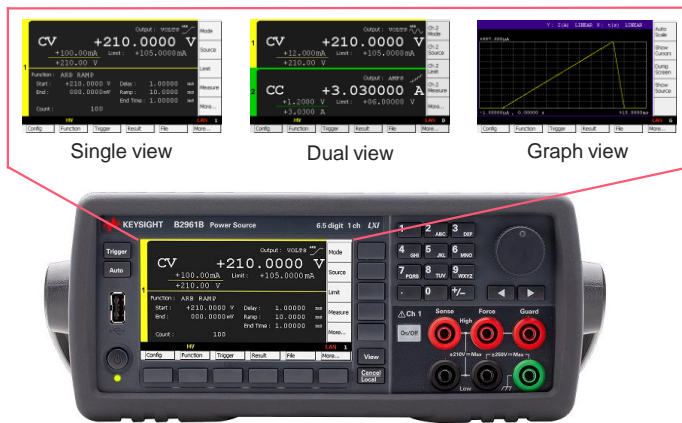

Figure 7. Three viewing modes provide you with flexible and efficient testing

Integrated voltage and current monitoring capability verify output with 4.5 digit resolution

The B2961B/B2962B has a built-in voltage and current monitoring feature that enables you to verify the actual voltage and current output. You can view the sourced voltage and current values with 4.5 digit numeric resolution in both single and dual viewing modes. With minimum voltage and current measurement resolution of 10 μ V and 1 pA (respectively), a digital multi-meter (DMM) is not necessary for measurement verification.

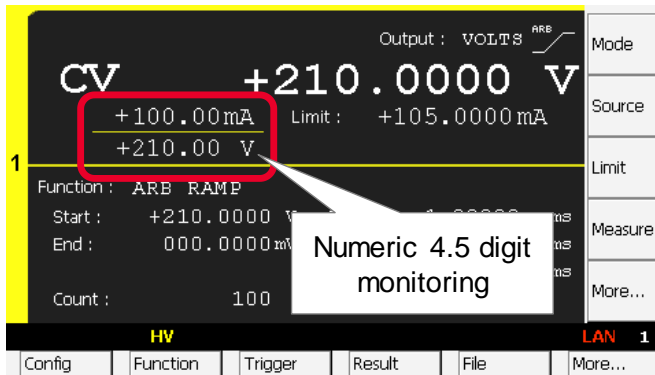

Figure 8. Perform quick status checks with 4.5 digit numeric display

Time domain waveform viewer facilitates quick check and debug of output waveforms

In addition to the numeric monitoring, the B2961B/B2962B Power Source has a time domain waveform viewing capability (Figure 9). For most power supplies and sources, you cannot view the actual waveform you are applying to your device or sample without using some other sort of external instrument. The B2961B/B2962B's time domain monitoring capability displays applied waveforms on its LCD display (Graph View mode), enabling you to verify that you are applying the correct signal to your DUT.

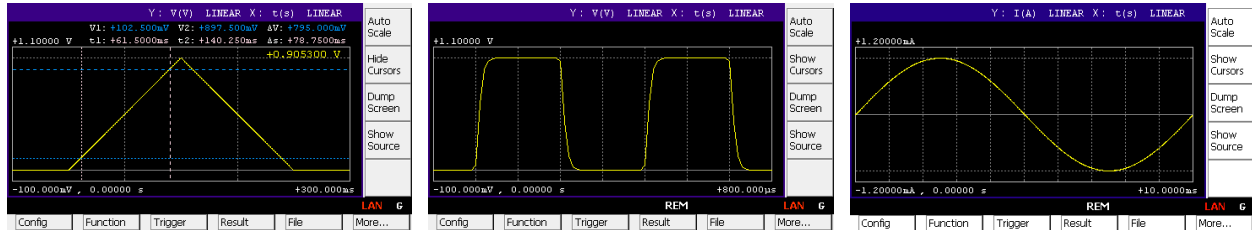

Figure 9. Graph View allows you to view output waveform in the time domain

GUI Based Intuitive Front Panel Design with Rich Standard Interfaces for Your Bench-Top Needs

In addition to the graphical user interface and easy-to-use front panel, the B2961B/B2962B integrates standard interfaces such as USB 2.0, LAN (LXI class C compliant), digital I/O and GPIB in a bench-top instrument form. The optional filters are well designed for the B2961B/B2962B and easy to attach and detach to/from front/rear channels.



Figure 10. Front/rear panel at a glance

Flexible Source Functions Beyond a DC Instrument Remove Your Test Restrictions

Pre-defined and arbitrary waveforms increase your test and evaluation flexibility

The B2961B/B2962B features full-fledged test and evaluation beyond conventional static DC testing. The pre-defined waveform generation capability provides six waveforms: sinusoidal, exponential, ramp, triangle, square and trapezoidal. In addition to these commonly used waveforms, you can set user-defined arbitrary waveforms with up to 100,000 points of setting. These flexible output capabilities should help you make deeper evaluation of your devices/samples that you've tested with other instruments than power supplies and sources.

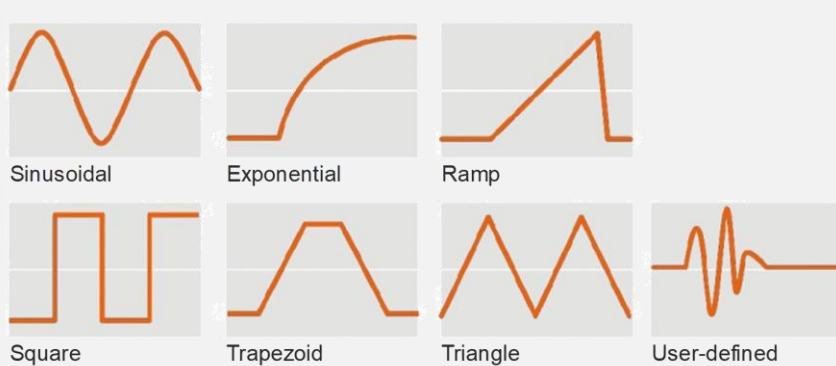

Figure 11. Convenient built-in waveform generation capabilities

Precision and wide voltage/current waveform generation

The arbitrary waveform generation capability of B2961B/B2962B can generate both precision voltage and current waveforms in 1 mHz –10 kHz frequency range. Although some of conventional voltage/current source instruments feature a waveform generation capability, the output waveforms do not have enough accuracy as shown in Figure 12A. In contrast, as shown in Figure 12B, The B2961B/B2962B can generate cleaner and more precision waveforms for more sensitive device/sample testing. You can also make use of the same output voltage/current ranges (210 V/3 A) and the same resolutions (100 nV/10 fA) as those of original DC voltage/current specifications. This outstanding capability helps you make precision test and evaluation even in time domain.

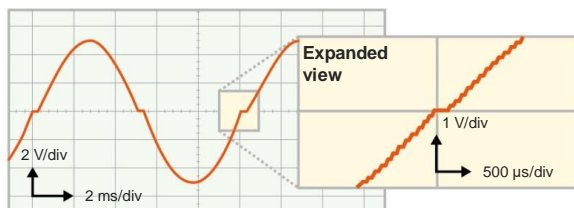

Figure 12A. Sinusoid waveform comparison at 100 Hz (Conventional voltage source)

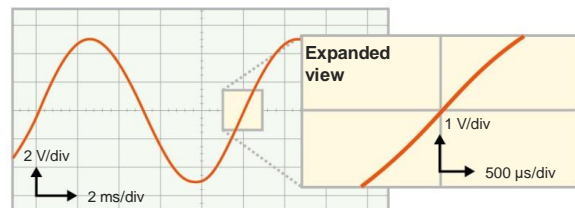

Figure 12B. Sinusoid waveform comparison at 100 Hz (B2961B/B2962B)

Preview of output waveform and simple user interface helps quick and reliable test

The B2961B/B2962B provides convenient and user-friendly interface for this arbitrary waveform generation capabilities. The preview mode shows the waveform shape on the same display that you set the waveform parameters, and enables you to check the forcing waveform shape in advance. This well-considered user interface provides you with an intuitive test environment, and improves your test and evaluation efficiency.



Figure 13. The preview of waveform you have just set

Programmable Output Resistance and DC Voltage/Current Output Emulation Capabilities Solve Real-World Measurement Challenges

The B2961B/B2962B's programmable output resistance function provides flexible measurement capabilities

The B2961B/B2962B has a programmable output resistance feature that allows you to control the output behavior of the power source. It supports two test modes, constant and V/I emulation, to provide maximum flexibility and versatility. Constant mode allows you to specify an output resistance value (either positive or negative) such that the output will respond exactly as if the specified resistance value were in series (voltage source mode) or in parallel (current source mode) with the source output. The constant mode can emulate resistance values over a wide range, and the negative resistance capability is particularly useful for cancelling out unwanted external resistances. For example, you can use the negative resistance feature to eliminate the resistance of long connection wires without the need to use a 4-wire (Kelvin) connection scheme. This is especially useful in situations where a 4-wire measurement is not possible due to packaged device limitations or to the absence of sense pads for probing.

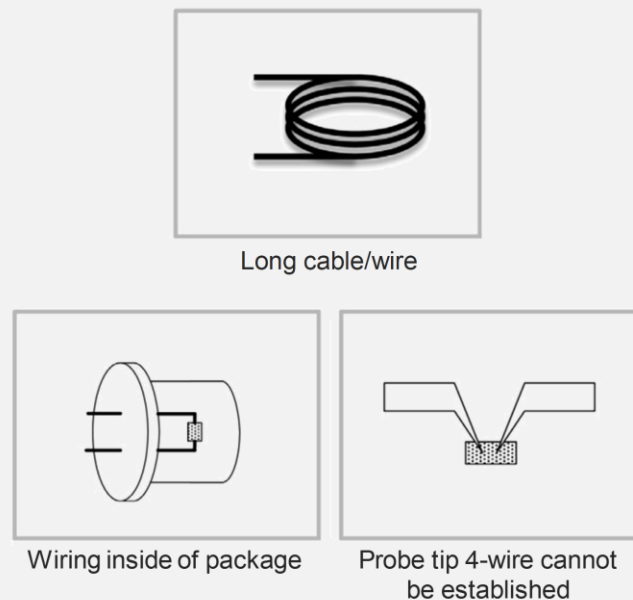

Figure 14. Measurement situations that benefit from Programmable Output Resistance's Constant mode feature

DC voltage/current characteristic emulation feature provides powerful bench-top analysis capabilities

The programmable output resistance's V/I emulation mode function allows you to simulate any DC voltage/current output characteristic. You can specify up to 16 voltage and current points to create the desired DC electrical characteristic. Since in this mode The B2961B/B2962B responds exactly like the equivalent device or sample, it is useful for simulating electrical behavior when an actual component is not available as well as for testing corner cases. In the example shown in Figure 15, the output of an active device (solar cell) is simulated using the V/I emulation mode function. This ability to simulate both active and passive devices provides unprecedented power and flexibility in a compact bench-top form factor. (Figure 16).

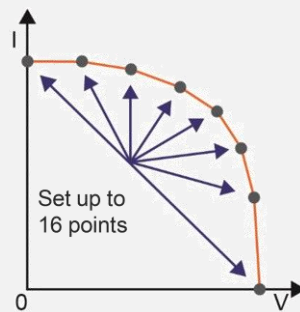

Figure 15. In V/I emulation mode you can specify up to 16 voltage/ current points to synthesize a desired electrical characteristic

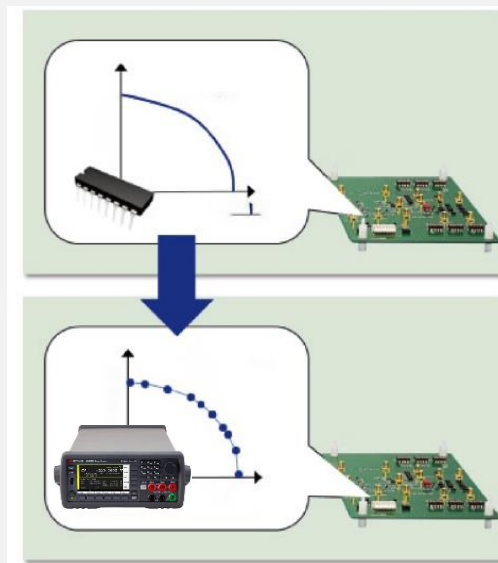
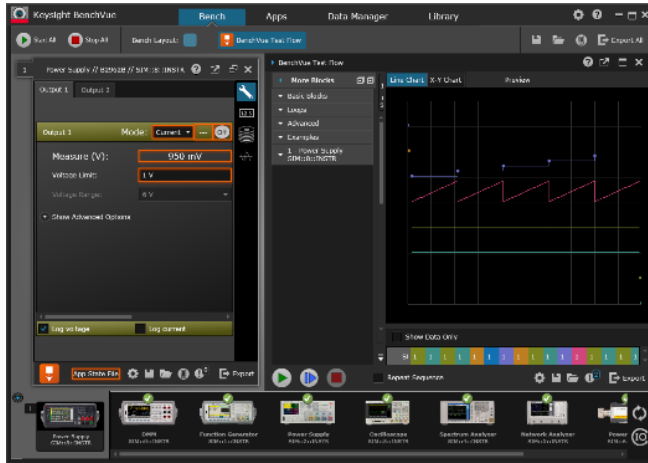

Figure 16. The B2961B/B2962B can emulate the DC voltage/current output characteristics of many devices and samples

Multiple Communication Methods and Software Provide Flexible and Convenient Remote Control Options

BenchVue

BenchVue allows you to control The B2961B/B2962B as voltage/current sources from a PC without the need to do any programming. In addition, because BenchVue supports a wide variety of Keysight instruments (oscilloscopes, meters, etc.) it is a good choice when you need to integrate together many different types of instruments on a benchtop.



Graphical Web Interface

The B2961B/B2962B has a built-in web server that allows it to be controlled using a web browser. This allows you to enjoy the convenience of external PC control without the need for any special software. Simply connect your computer to the instrument via its LAN port, type in the IP address of The B2961B/B2962B unit and begin making interactive tests.

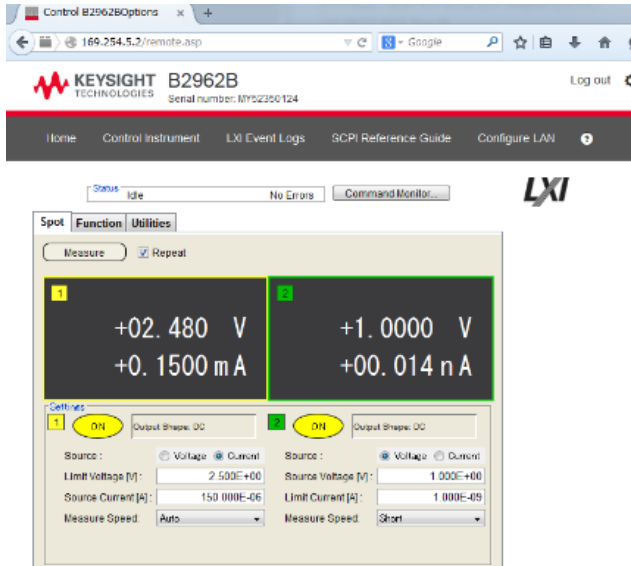

Quick I/V Measurement Software

Keysight supplies PC-based Quick I/V Measurement Software with The B2961B/B2962B at no charge. This software makes it easy to quickly setup and perform voltage or current sourcing and to display measurement data in tables and graphs without the need to program. Using Keysight Quick IV software you can control up to four instrument channels.

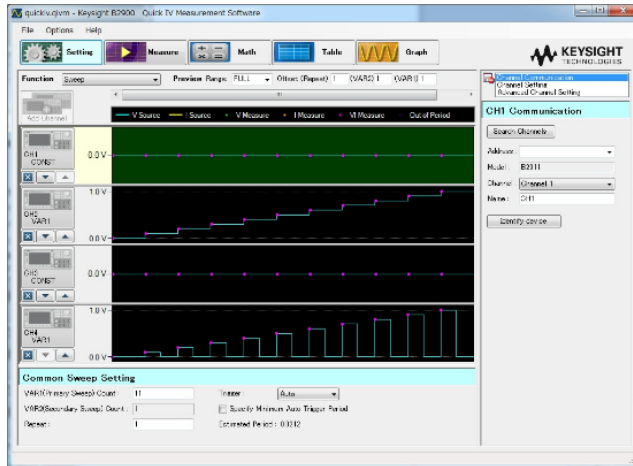

Ready-to-use instrument drivers simplify Programming

For users that want to create their own customized software, IVI-C and IVI-COM drivers for The B2961B/B2962B are available. In addition, National Instruments LabView drivers are available at NI.COM.

Key Specifications

| | | B2961B/ B2962B | B2961B/B2962B with High Current Ultra Low Noise Filter | B2961B/B2962B with Ultra Low Noise Filter | B2961B/B2962B with Low Noise Filter | |
|--------------------------------|--|---|--|---|-------------------------------------|-----------------------|
| Number of channel | | 1 or 2 | 1 or 2 | 1 or 2 | 1 or 2 | |
| Output | DC or arbitrary waveform output | Max. voltage | ± 210 V | ± 21 V | ± 42 V | ± 210 V |
| | | Max. current | ± 3.03 A | ± 500 mA | ± 105 mA | ± 3.03 A |
| | Pulsed | Max. voltage | ± 200 V | ± 21 V | ± 42 V | ± 200 V |
| | | Max. current | ± 10.5 A | ± 500 mA | ± 105 mA | ± 3.03 A ⁴ |
| | Maximum power | 31.8 W | 10.5 W | 4.4 W | 31.8 W | |
| Output polarity | | Bipolar (4-quadrant operation) | | | | |
| Source resolution | Digit | 6.5 digit | 6.5 digit | 6.5 digit | 6.5 digit | |
| | Minimum resolution | 100 nV /10 fA | 100 nV /10 pA | 100 nV /10 pA | 100 nV /10 fA | |
| Output capability | DC | Yes | Yes | Yes | Yes | |
| | Pulsed | Yes | Only voltage output | Only voltage output | Only voltage output | |
| | Sweep DC/Pulse/List | Yes | Only voltage output | Only voltage output | Only voltage output | |
| | Arbitrary wave form | Yes | Only voltage output | Only voltage output | Only voltage output | |
| Noise ¹ | 0.1 to 10 Hz | ≤ 5 μVpp | ≤ 5 μVpp | ≤ 5 μVpp | ≤ 5 μVpp | |
| | 10 to 20 MHz | 3 mVrms | 10 μVrms (1 nVrms/√Hz @ 10 kHz) | 10 μVrms (1 nVrms/√Hz @ 10 kHz) | 350 μVrms | |
| Measurement capability | | 4.5 digit built-in voltage/current monitor | | | | |
| Source/ monitor ranges | Voltage | 200 mV to 200 V | 200 mV to 20 V ² | 200 mV to 200 V ³ | 200 mV to 200 V | |
| | Current | 10 nA to 10 A | 1 mA to 1 A | 10 μA to 100 mA | 10 μA to 3 A | |
| Programmable output resistance | Constant R | Yes | No | No | No | |
| | V/I emulation | Yes | No | No | No | |
| View mode | Single view | Yes | Yes | Yes | Yes | |
| | Waveform preview | Yes | Yes | Yes | Yes | |
| | Dual View | Only 2 ch model (B2962B) | | | | |
| | Graph view (time-domain voltage/current waveform viewer) | Yes | Yes | Yes | Yes | |
| Max capacitive load | | 0.01 μF (normal mode) | 50 μF | 50 μF | 1 mF | |
| Interface | | GPIO, USB 2.0, LAN and digital I/O(LXI Core Conformant) | | | | |

1. Supplemental characteristics.
2. Maximum voltage output is limited to 21 V for 20 V range.
3. Maximum voltage output is limited to 42 V for 200 V range.
4. 10 A pulse range is not supported.

Specifications

Specification conditions

| | |
|--------------------------|--|
| Temperature | 23 °C ± 5 °C |
| Humidity | 30% to 80% RH |
| After 60 minutes warm-up | Ambient temperature change less than ± 3 °C after self-calibration execution |
| Calibration period | 1 year |
| Measurement speed | 1 PLC (power line cycle) |

Maximum voltage and current

| | Max voltage | Max current |
|---------------------------|-------------|----------------------|
| DC or pulsed ¹ | 210 V | 0.105 A |
| | 21 V | 1.515 A ² |
| | 6 V | 3.03 A ² |
| Pulsed only ¹ | 200 V | 1.515 A |
| | 6 V | 10.5 A |

1. See "Maximum pulse width and duty cycle" in Pulse Source Supplemental Characteristics for applicable maximum voltage and current.
2. Max current limitation: For 21 V/1.515 A and 6 V/3.03 A ranges, total max current is limited by the table below for using 2 channels. Max current is not limited for using 1 channel only.

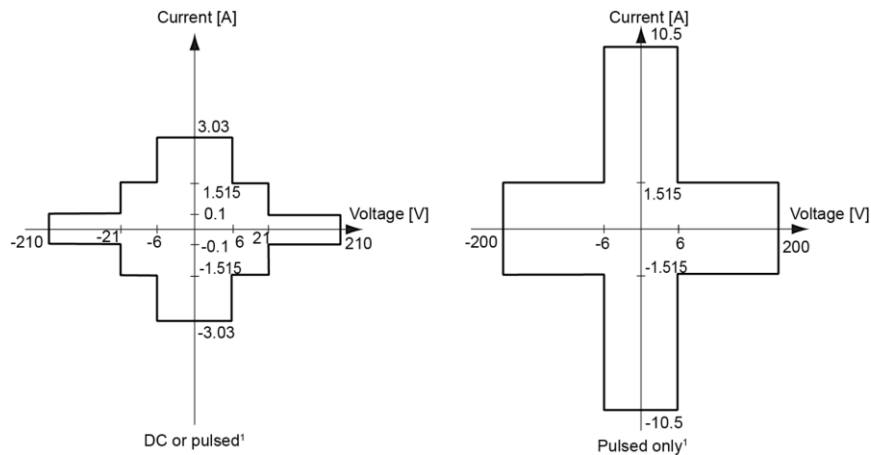

Maximum current limitation

| Ch1 voltage | Ch2 voltage | Max total current limitation of Ch1 and Ch2 |
|--------------------|--------------------|---|
| ± (0 V < V ≤ 6 V) | ± (0 V < V ≤ 6 V) | Ch1 current + Ch2 current ≤ 4 A |
| ± (0 V < V ≤ 6 V) | ± (6 V < V ≤ 21 V) | Ch1 current + Ch2 current x 1.6 ≤ 4 A |
| ± (6 V < V ≤ 21 V) | ± (0 V < V ≤ 6 V) | Ch1 current + Ch2 current x 0.625 ≤ 2.5 A |
| ± (6 V < V ≤ 21 V) | ± (6 V < V ≤ 21 V) | Ch1 current + Ch2 current ≤ 2.5 A |

DC voltage source specifications

| Range | Programming resolution | Accuracy \pm (% reading + offset) | Noise (peak to peak) 0.1 Hz to 10 Hz ¹ | Max voltage (over range) |
|--------------|------------------------|-------------------------------------|---|--------------------------|
| ± 200 mV | 100 nV | $\pm (0.015 \% + 225 \mu\text{V})$ | $\leq 5 \mu\text{V}$ | ± 210 mV |
| ± 2 V | 1 μV | $\pm (0.02 \% + 350 \mu\text{V})$ | $\leq 15 \mu\text{V}$ | ± 2.1 V |
| ± 20 V | 10 μV | $\pm (0.015 \% + 5 \text{ mV})$ | $\leq 150 \mu\text{V}$ | ± 21 V |
| ± 200 V | 100 μV | $\pm (0.015 \% + 50 \text{ mV})$ | $\leq 1.5 \text{ mV}$ | ± 210 V |

1. Supplemental characteristics.

DC current source specification

| Range | Programming resolution | Accuracy \pm (% reading + offset) | Noise (peak to peak) 0.1 Hz to 10 Hz ¹ | Max voltage (over range) |
|-------------------------|------------------------|---|---|--------------------------|
| ± 10 nA | 10 fA | $\pm (0.10 \% + 50 \text{ pA})$ | $\leq 1 \text{ pA}$ | ± 10.5 nA |
| ± 100 nA | 100 fA | $\pm (0.06 \% + 100 \text{ pA})$ | $\leq 2 \text{ pA}$ | ± 105 nA |
| ± 1 μA | 1 pA | $\pm (0.025 \% + 500 \text{ pA})$ | $\leq 20 \text{ pA}$ | ± 1.05 μA |
| ± 10 μA | 10 pA | $\pm (0.025 \% + 1.5 \text{ nA})$ | $\leq 60 \text{ pA}$ | ± 10.5 μA |
| ± 100 μA | 100 pA | $\pm (0.02 \% + 25 \text{ nA})$ | $\leq 1 \text{ nA}$ | ± 105 μA |
| ± 1 mA | 1 nA | $\pm (0.02 \% + 200 \text{ nA})$ | $\leq 6 \text{ nA}$ | ± 1.05 mA |
| ± 10 mA | 10 nA | $\pm (0.02 \% + 2.5 \mu\text{A})$ | $\leq 100 \text{ nA}$ | ± 10.5 mA |
| ± 100 mA | 100 nA | $\pm (0.02 \% + 20 \mu\text{A})$ | $\leq 600 \text{ nA}$ | ± 105 mA |
| ± 1 A | 1 μA | $\pm (0.03 \% + 1.5 \text{ mA})$ | $\leq 20 \mu\text{A}$ | ± 1.05 A |
| ± 1.5 A | 1 μA | $\pm (0.05 \% + 3.5 \text{ mA})$ | $\leq 20 \mu\text{A}$ | ± 1.515 A |
| ± 3 A | 10 μA | $\pm (0.4 \% + 7 \text{ mA})$ | $\leq 60 \mu\text{A}$ | ± 3.03 A |
| ± 10 A ² | 10 μA | $\pm (0.4 \% + 25 \text{ mA})$ ³ | | ± 10.5 A |

1. Supplemental characteristics.

2. 10 A range is available only for pulse mode, not available for DC mode.

3. Measurement speed: 0.01 PLC.

Source Supplemental Characteristics

Pulsing capabilities

| | |
|------------------------------------|---|
| Minimum programmable pulse width | 50 μ s |
| Pulse width programming resolution | 1 μ s |
| Pulse width definition | The time from 10 % leading to 90 % trailing edge as follows |

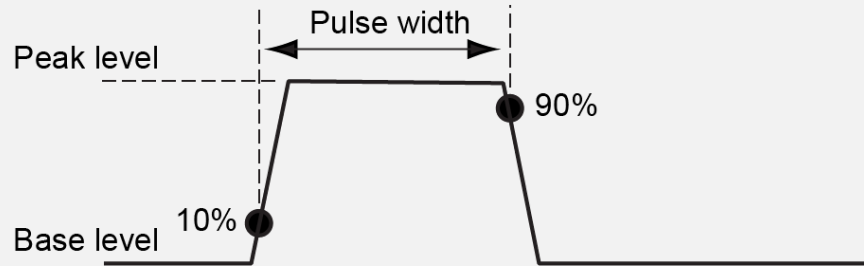

Maximum pulse width and duty cycle

| | Pulsed | | | | | DC | |
|--------------|-------------|----------------------|----------------------|-------------------------|----------------|-------------|----------------------|
| | Max voltage | Max peak current | Max base current | Pulse width | Max duty cycle | Max voltage | Max current |
| DC or pulsed | 210 V | 0.105 A | 0.105 A | 50 μ s to 99999.9 s | 99.9999 % | 210 V | 0.105 A |
| | 21 V | 1.515 A ¹ | 1.515 A ¹ | 50 μ s to 99999.9 s | 99.9999 % | 21 V | 1.515 A ¹ |
| | 6 V | 3.03A ¹ | 3.03 A ¹ | 50 μ s to 99999.9 s | 99.9999 % | 6 V | 3.03 A ¹ |
| Pulsed only | 200 V | 1.515A | 50 mA | 50 μ s to 2.5 ms | 2.5 % | | |
| | 180 V | 1.05 A | 50 mA | 50 μ s to 10 ms | 2.5 % | | |
| | 6 V | 5.25 A | 0.1 A | 50 μ s to 3 ms | 3.0 % | | |
| | 6 V | 10.5 A | 0.5 A | 50 μ s to 1 ms | 2.5 % | | |

1. Max current limitation: For 21 V/1.515 A and 6 V/3.03 A ranges, total max current is limited by the table in page 19 for using 2 channels. Max current is not limited for using 1 channel only.

Minimum pulse width at the given voltage, current and settling conditions

| Source value | Limit value | Load | Source settling (% of range) | Min pulse width |
|---------------------|------------------|---------------------------|------------------------------|---------------------|
| 200 V | 1.5 A | 200 Ω | 0.1% | 1 ms |
| 6 V | 10.5 A | 0.6 Ω | 0.1% | 0.2 ms |
| 1.5 A | 200 V | 65 Ω | 0.1% | 2.5 ms |
| 10.5 A | 6 V | 0.5 Ω | 0.1% | 0.2 ms |
| 10.5 A ¹ | 6 V ¹ | 0.1 Ω ¹ | 0.1 % ¹ | 0.1 ms ¹ |

1. Transient speed mode is set to FAST.

Sweep capabilities

| | |
|--|--|
| Sweep mode | Linear, logarithmic (log) or list |
| Sweep direction | Single or double |
| Type | DC, or pulse |
| Number of steps | 1 to 100,000 |
| Min programmable value to create list sweep waveform | Minimum 10 μ s with 1 μ s resolution |

Arbitrary Waveform Generation Capabilities

| Pre-defined waveforms | |
|--|---|
| Supported waveforms | Sine, Square, Ramp, Triangle, Trapezoid and Exponential |
| Frequency | 1 mHz to 10 kHz |
| Programmable frequency/timing resolution | 1 μ Hz nominal (sine), 250 ns (waveforms other than sine) |
| Frequency accuracy of time base | \pm 50 ppm |
| Linearity (best-fit) | Voltage Source \pm 0.01% ¹ , Current Source \pm 0.01% ² |
| THD | Voltage Source -90 dB ³ , Current Source -90 dB ⁴ |

1. \pm 1 V, \pm 10 V, \pm 200 V, open load.

2. \pm 10 mA 1 k Ω load, \pm 100 mA 100 Ω load.

3. \pm 1 V, \pm 10 V, \pm 180 V, open load.

4. \pm 1 μ A 100 k Ω load, \pm 10 μ A 100 k Ω load, \pm 10 mA 100 Ω load.

| User-defined waveforms | |
|------------------------|--|
| Waveform length | 1 to 100,000 points |
| Sample rate | 0.001 to 100,000 Sa/s, 250 ns resolution |
| Storage | Non-volatile memory and USB memory are both available. Non-volatile memory can store one waveform with a length of up to 2500 points. USB memory can store waveforms of up to 100k points. |

Output characteristics

| | |
|--|--|
| Temperature coefficient (0 to 18 °C and 28 °C to 50 °C) | $\pm (0.1 \times \text{Accuracy})/^{\circ}\text{C}$ |
| Max output power and source/sink limits | 31.8 W |
| | $\pm 6 \text{ V} @ \pm 3.03 \text{ A}$, $\pm 21 \text{ V} @ \pm 1.515 \text{ A}$, $\pm 210 \text{ V} @ 105 \text{ mA}$, four quadrant source or sink operation |
| Output location | Channel 1 at front, and channel 2 at rear |
| Output connectors | Banana jack. Triaxial connections are recommended for sourcing less than 1 nA. A banana jack to triaxial adapter is available for low current source. |
| Low terminal connection | Chassis grounded or floating |
| Sensing Modes | 2-wire or 4-wire (Remote-sensing) connections |
| Maximum load | Normal mode: 0.01 μF |
| | High capacitance mode: 50 μF |
| DC floating voltage | Max $\pm 250 \text{ V}$ DC between low force and chassis ground |
| Guard offset voltage (V source) | < 4 mV |
| Remote sense operation range | Max voltage between High Force and High Sense = 3 V |
| | Max voltage between Low Force and Low Sense = 3 V |
| Common mode isolation | > 1 G Ω , < 4500 pF |
| Max sense lead resistance | 1 k Ω for rated accuracy |
| Sense input impedance | > 10 G Ω |
| Current limit/compliance | Accuracy is same as current source. Min value is 1 % of range, or 1 nA in 10 nA range. |
| Voltage limit/compliance | Accuracy is same as voltage source. Min value is 1 % of range, or 20 mV in 200 mV range. |
| Over range | 101 % of source range for 1.5 A and 3 A ranges. 105 % of source range other than 1.5 A and 3 A ranges. No over range for 200 V range with current exceeding 105 mA pulse only condition. |
| Over temperature protection | Output turns off then resets at over temperature sensed internally |

Voltage source

| | | | |
|---------------------------------------|---|---------------------|---------------------|
| Settling time | Time required to reach within 0.1 % of final value at open load condition. Step is 10 % to 90 % range | | |
| | 200 mV, 2 V ranges | < 50 μ s | |
| | 20 V range | < 110 μ s | |
| | 200 V range | < 70 μ s | |
| Noise 10 Hz to 20 MHz | < 3 mVrms, 20 V range, without external filter | | |
| V source overshoot | < \pm (0.1 % + 10 mV). Step is 10 % to 90 % range, resistive load | | |
| Voltage source range change overshoot | \leq 250 mV. 100 k Ω load, 20 MHz bandwidth | | |
| Line regulation/load regulation | Included in voltage source specifications | | |
| Load transient recovery time | Time to recover to within the settling band following a load change. | | |
| | Current change | 100 mA ¹ | 800 mA ² |
| | Settling band | \pm 20 mV | \pm 20 mV |
| | Time | 10 μ s | 30 μ s |

1. At a load change to change the flowing current from +50 mA to +150 mA, 10 V voltage force, 20 V range, 1 A limit.
2. At a load change to change the flowing current from +100 mA to +900 mA, 10 V voltage force, 20 V range, 1.5 A limit.

| Slew rate/small signal bandwidth | | | | | |
|----------------------------------|------------------------|-------------------------|-------------------------|-------------------------|-----------------|
| Current range | Voltage range | | | | Load resistance |
| | 200 mV | 2 V | 20 V | 200 V | |
| 1 mA | 44 mV/ μ s, 28 kHz | 57 mV/ μ s, 18 kHz | 57 mV/ μ s, 28 kHz | 57 mV/ μ s, 28 kHz | 10 M Ω |
| 10 mA | 44 mV/ μ s, 28 kHz | 360 mV/ μ s, 20 kHz | 360 mV/ μ s, 17 kHz | 360 mV/ μ s, 28 kHz | 10 M Ω |
| 100 mA | 28 mV/ μ s, 28 kHz | 28 mV/ μ s, 20 kHz | 28 mV/ μ s, 28 kHz | 57 mV/ μ s, 28 kHz | 10 M Ω |
| 1 A | 25 mV/ μ s, 28 kHz | 25 mV/ μ s, 28 kHz | 25 mV/ μ s, 28 kHz | | 10 M Ω |
| 1.5 A | 36 mV/ μ s, 28 kHz | 36 mV/ μ s, 18 kHz | 36 mV/ μ s, 28 kHz | | 10 M Ω |
| 3 A | 27 mV/ μ s, 28 kHz | 27 mV/ μ s, 28 kHz | 27 mV/ μ s, 28 kHz | | 10 M Ω |

Note: Slew rate and small signal bandwidth can be down to -20% in maximum.

Current source

| | | |
|---------------------------------------|---|---------------|
| Settling time | Time required to reach within 0.1 % of final value at open load condition. Step is 10 % to 90 % range | |
| | 10 nA, 100 nA ranges | < 10 ms |
| | 1 μ A range | < 500 μ s |
| | 10 μ A, 100 μ A ranges | < 250 μ s |
| | 1 mA to 3 A ranges | < 80 μ s |
| I source overshoot | < \pm 0.1 % (< \pm 0.3 % for 3 A range). Step is 10 % to 90 % range, resistive load | |
| Current source range change overshoot | \leq 250 mV/R load, 20 MHz bandwidth | |
| Line regulation/load regulation | Included in current source specifications. | |

| Slew rate/small signal bandwidth | | | | | |
|----------------------------------|-----------------------------|------------------------------|------------------------------|------------------------------|-----------------|
| Current range | Voltage range | | | | Load resistance |
| | 200 mV | 2 V | 20 V | 200 V | |
| 1 mA | 94 μ A/ μ s, 21 kHz | 160 μ A/ μ s, 21 kHz | 160 μ A/ μ s, 21 kHz | 150 μ A/ μ s, 21 kHz | 100 Ω |
| 10 mA | 94 μ A/ μ s, 21 kHz | 670 μ A/ μ s, 21 kHz | 900 μ A/ μ s, 21 kHz | 900 μ A/ μ s, 21 kHz | 100 Ω |
| 100 mA | 8 mA/ μ s, 10 kHz | 8 mA/ μ s, 10 kHz | 8 mA/ μ s, 10 kHz | 12 mA/ μ s, 21 kHz | 1 Ω |
| 1 A | 78 mA/ μ s, 12 kHz | 94 mA/ μ s, 12 kHz | 92 mA/ μ s, 12 kHz | | 0.1 Ω |
| 1.5 A | 125 mA/ μ s, 12 kHz | 135 mA/ μ s, 12 kHz | 140 mA/ μ s, 12 kHz | | 0.1 Ω |
| 3 A | 250 mA/ μ s, 13 kHz | 270 mA/ μ s, 13 kHz | 260 mA/ μ s, 13 kHz | | 0.041 Ω |

Note: Slew rate and small signal bandwidth can be down to -20% in maximum.

High capacitance mode

The high capacitance mode supports sources and measurements when the load capacitance is greater than 0.01 μF . In high capacitance mode the maximum allowed load capacitance value is 50 μF .

| | | | |
|---|----------------------------|---|--|
| Voltage output settling time | | Time required to reach within 0.1 % of final value with 4.7 μF capacitive load on a fixed range at specified current range and limit value | |
| | | 200 mV, 2 V ranges | 600 μs , at 1 A limit |
| | | 20 V range | 1.5 ms, at 1 A limit |
| | | 200 V range | 20 ms, at 100 mA limit |
| Current measurement settling time | | Time required to reach 0.1 % of final value after the voltage source stabilized in a fixed range. V_{out} is 5 V unless noted. | |
| | | 1 μA range | 230 ms |
| | | 10 μA , 100 μA ranges | 23 ms |
| | | 1 mA, 10 mA ranges | 0.23 ms |
| | | 100 mA to 3 A ranges | 100 μs |
| Mode change delay | Delay into high cap mode | 1 μA range | 230 ms |
| | | 10 μA , 100 μA ranges | 23 ms |
| | | 1 mA to 3 A ranges | 1 ms |
| | Delay out of high cap mode | All ranges | 10 ms |
| Noise 10 Hz to 20 MHz (20 V range) | | 4.5 mVrms | |
| Voltage source range change overshoot (20 V range or below) | | < 250 mV, 20 MHz bandwidth | |
| High capacitance mode working conditions | | V/I mode | Voltage source mode only |
| | | Range | Current measurement range is limited to fixed range only. 10 nA and 100 nA ranges are not available. |
| Current limit | | $\geq 1 \mu\text{A}$ | |

Programmable output resistance ¹

In its default state The B2961B/B2962B behaves like either an ideal voltage source with a negligibly small source resistance or an ideal current source with a huge source resistance. The programmable output resistance feature allows you to specify either a particular output resistance or a specific voltage versus current source characteristic. This feature is ideal for emulating a wide variety of devices (such as batteries, photovoltaic cells, sensors, transducers, etc.) that are otherwise difficult to simulate. Emulation mode allows you to program a non-linear resistance. You specify the desired voltage/current characteristic using a tabular format.

| Mode | | Constant or V/I Emulation |
|---|--|---|
| Programmable resistance range in Constant mode | Series resistance (Rs) at voltage source | (Load Resistance/2) ≤ Rs ≤ Load Resistance, for resistive load |
| | | Rs ≤ 25 Ω at 3 A range, ≤ 100 Ω at 1 A and 1.5 A ranges, ≤ 1 kΩ at 100 mA range, or ≤ 10 kΩ at other ranges |
| | | Rs can be limited by capacitive load |
| | Shunt resistance (Rsh) at current source | Load Resistance ≤ Rsh ≤ 2 GΩ, for resistive load |
| Rsh ≥ 10 MΩ at 10 nA and 100 nA ranges, ≥ 1 M Ω at other ranges | | |
| Rsh can be limited by capacitive load | | |
| Max number of points in Emulation mode | | 16 (piecewise linear interpolation between points) |

1. Programmable output resistance is only available for DC output.

External low noise filter supplemental characteristics

The B2961B/B2962B supports dedicated external low-noise filters; they are available as an option or as an accessory. They connect to the banana jack outputs of each B2961B/B2962B channel.

High Current Ultra Low Noise Filter (N1298A)

| | | | |
|------------------------------|--|--|--|
| Maximum output range | | 21 V / 500 mA (DC) | |
| Output connector | | BNC | |
| Output/residual resistance | | 10 Ω nominal (2-wire), 0.3 Ω nominal (4-wire. 4-wire connected inside of filter) | |
| Small signal bandwidth | | 23 Hz nominal (2-wire), 8 Hz nominal (4-wire) | |
| Source noise | Voltage | 0.1 to 10 Hz | Same as voltage specification |
| | | 10 to 20 MHz | 10 μ Vrms, 1nVrms $\sqrt{\text{Hz}}$ at 10 kHz (20 V / 100 mA range, 50 Ω load) |
| | Current | 0.1 to 10 Hz: | Same as current specification |
| | | 10 to 1 MHz | 8 μ Arms (20 V/1 A range, 2 Ω load) |
| Source setting time | Voltage ¹ | 80 ms (2-wire), 140 ms (4-wire) | |
| | Current ² | 11 ms (2-wire), 150 ms (4-wire) | |
| Load transient recovery time | Time to recover to within the settling band following a load change. | | |
| | Current change | 250 mA ³ | |
| | Settling band | \pm 20 mV | |
| | Time | 50 ms (2-wire), 85 ms (4-wire) | |
| Supported ranges | Voltage | 200 mV to 200 V ranges (21 V maximum) | |
| | Current | 1 mA to 1 A ranges (500 mA maximum) | |
| Maximum capacitive load | | 50 μ F (for 4-wire) | |
| Dimensions | | 41 mm H x 58.2 mm W x 141.5 mm D (When the filter is inserted to the output connector of B2961B/B2962B, the depth is 126.5 mm.) | |
| Weight | | 0.3 kg | |

1. Time required to reach within 0.1 % of final value at open load condition. Step is 10 % to 90 % range. At 20 V range, 500 mA limit/1 A range.
2. Time required to reach within 0.1 % of final value at short condition. Step is 10 % to 90 % range. At 500 mA (1 A) range, 20 V limit/20V range.
3. At a load change to change the flowing current from +10 mA to +260 mA, 10 V voltage force, 20 V range, 500 mA limit.

Note:

- The 10 A pulse range and programmable output resistance capability are not supported by external filters.
- For the current output, only DC is supported when using with external filters.
- The current measurement data monitored by the built-in voltage/current monitor can be influenced by the charge and discharge current of the capacitance inside of the filters.

Ultra Low Noise Filter (N1298B)

| | | | |
|------------------------------|--|---|---|
| Maximum output range | | 42 V / 105 mA (DC) | |
| Output connector | | BNC | |
| Output/residual resistance | | 50 Ω nominal (2-wire), 0.3 Ω nominal (4-wire. 4-wire connected inside of filter) | |
| Small signal bandwidth | | 23 Hz nominal (2-wire), 8 Hz nominal (4-wire) | |
| Source noise | Voltage | 0.1 to 10 Hz | Same as voltage specification |
| | | 10 to 20 MHz | 10 μ Vrms, 1 nVrms $\sqrt{\text{Hz}}$ at 10 kHz (20 V / 100 mA range, 50 Ω load) |
| | Current | 0.1 to 10 Hz: | Same as current specification |
| | | 10 to 1 MHz | 300 nArms (20 V/100 mA range, 10 Ω load) |
| Source setting time | Voltage ¹ | 80 ms (2-wire), 140 ms (4-wire) | |
| | Current ² | 11 ms (2-wire), 150 ms (4-wire) | |
| Load transient recovery time | Time to recover to within the settling band following a load change. | | |
| | Current change | 50 mA ³ | |
| | Settling band | \pm 20 mV | |
| | Time | 50 ms (2-wire), 85 ms (4-wire) | |
| Supported ranges | Voltage | 200 mV to 200 V ranges (42 V max) | |
| | Current | 10 μ A to 100 mA ranges (105 mA max) | |
| Maximum capacitive load | | 50 μ F (for 4-wire) | |
| Dimensions | | 41 mm H x 58.2 mm W x 141.5 mm D (When the filter is inserted to the output connector of B2961B/B2962B, the depth is 126.5 mm.) | |
| Weight | | 0.3 kg | |

1. Time required to reach within 0.1 % of final value at open load condition. Step is 10 % to 90 % range. At 20 V range, 100 mA limit/100 mA range.
2. Time required to reach within 0.1 % of final value at short condition. Step is 10 % to 90 % range. At 100 mA range, 20 V limit/20V range.
3. At a load change to change the flowing current from +10 mA to +60 mA, 10 V voltage force, 20 V range, 100 mA limit.

Note:

- The 10 A pulse range and programmable output resistance capability are not supported by external filters.
- For the current output, only DC is supported when using with external filters.
- The current measurement data monitored by the built-in voltage/current monitor can be influenced by the charge and discharge current of the capacitance inside of the filters.

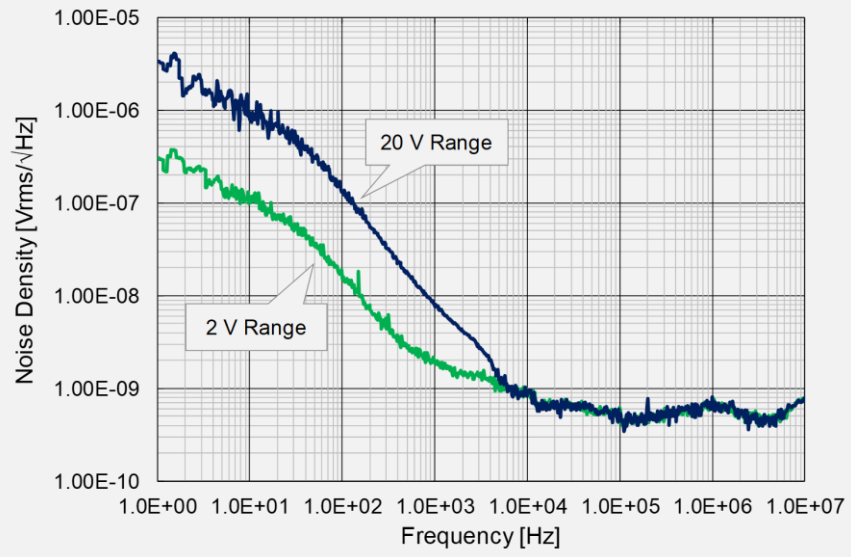

Low Noise Filter (N1298C)

| | | | |
|------------------------------|--|--|---|
| Maximum output range | | 210 V/3 A (DC) | |
| Output connector | | Banana, 2-wire/4-wire | |
| Output/residual resistance | | 0.3 Ω nominal (2-wire) | |
| Small signal bandwidth | | 2 kHz nominal (1 A and 3 A ranges), 800 Hz nominal (100 mA range) | |
| Source noise | Voltage | 0.1 to 10 Hz | Same as voltage specification |
| | | 10 to 20 MHz | 350 μ Vrms (20 V/1.5 A range, 50 Ω load) |
| | Current | 0.1 to 10 Hz: | Same as current specification |
| | | 10 to 1 MHz | 450 μ Arms (20 V/1.5 A range, 0.67 Ω load) |
| Source setting time | Voltage ¹ | 640 μ s (2-wire/4-wire) | |
| | Current ² | 1.2 ms (2-wire/4-wire) | |
| Load transient recovery time | Time to recover to within the settling band following a load change. | | |
| | Current change | 800 mA ³ | |
| | Settling band | \pm 20 mV | |
| | Time | 450 μ s (2-wire), 650 μ s (4-wire) | |
| Supported ranges | Voltage | 200 mV to 200 V ranges (210 V max) | |
| | Current | 10 μ A to 3 A ranges (3 A max) | |
| Maximum capacitive load | | 1 mF | |
| Dimensions | | 41.5 mm H x 58.2 mm W x 127.5 mm D (When the filter is inserted to the output connector of B2961B/B2962B, the depth is 112.5 mm.) | |
| Weight | | 0.25 kg | |

1. Time required to reach within 0.1 % of final value at open load condition. Step is 10 % to 90 % range. At 20 V range, 1.5 A limit/1.5 A range.
2. Time required to reach within 0.1 % of final value at short condition. Step is 10 % to 90 % range. At 1.5 A range, 20 V limit/20V range.
3. At a load change to change the flowing current from +100 mA to +900 mA, 10 V voltage force, 20 V range, 1.5 A limit.

Note:

- The 10 A pulse range and programmable output resistance capability are not supported by external filters.
- For the current output, only DC is supported when using with external filters.
- The current measurement data monitored by the built-in voltage/current monitor can be influenced by the charge and discharge current of the capacitance inside of the filters.

Built-in voltage/current monitor specifications

Voltage measurement specifications

| Range | Measurement resolution | Accuracy (% reading + offset) |
|----------|------------------------|-------------------------------|
| ± 200 mV | 10 µV | ± (0.015 % + 225 µV) |
| ± 2 V | 100 µV | ± (0.02 % + 350 µV) |
| ± 20 V | 1 mV | ± (0.015 % + 5 mV) |
| ± 200 V | 10 mV | ± (0.015 % + 50 mV) |

Current measurement specifications

| Range | Measurement resolution | Accuracy (% reading + offset) |
|---------------------|------------------------|--------------------------------|
| ± 10 nA | 1 pA | ± (0.10 % + 50 pA) |
| ± 100 nA | 10 pA | ± (0.06 % + 100 pA) |
| ± 1 µA | 100 pA | ± (0.025 % + 500 pA) |
| ± 10 µA | 1 nA | ± (0.025 % + 1.5 nA) |
| ± 100 µA | 10 nA | ± (0.02 % + 25 nA) |
| ± 1 mA | 100 nA | ± (0.02 % + 200 nA) |
| ± 10 mA | 1 µA | ± (0.02 % + 2.5 µA) |
| ± 100 mA | 10 µA | ± (0.02 % + 20 µA) |
| ± 1 A | 100 µA | ± (0.03 % + 1.5 mA) |
| ± 1.5 A | 100 µA | ± (0.05 % + 3.5 mA) |
| ± 3 A | 1 mA | ± (0.4 % + 7 mA) |
| ± 10 A ¹ | 1 mA | ± (0.4 % + 25 mA) ² |

1. 10 A range is available only for pulse mode, not available for DC mode.
2. Measurement speed: 0.01 PLC.

Built-in voltage/current monitor supplemental characteristics

| | |
|---|--|
| Temperature coefficient (0 to 18 °C and 28 °C to 50 °C) | $\pm (0.1 \times \text{Accuracy})/^{\circ}\text{C}$ |
| Over range | 102 % of measurement range for 1.5 A and 3 A ranges |
| | 106 % of measurement range other than 1.5 A and 3 A ranges |
| Voltage measurement range change overshoot | < 250 mV. 100 k Ω load, 20 MHz bandwidth |
| Current measurement range change overshoot | < 250 mV/R load, 20 MHz bandwidth |

Derating accuracy for measurement speed less than 1 PLC: Add % of range using the following table for measurement with PLC < 1.

| | Voltage range | | Current range | | | |
|-----------|---------------|--------------|---------------|--------|---------------------------|------------|
| | 0.2 V | 2 V to 200 V | 10 nA | 100 nA | 1 μA to 100 mA | 1 A to 3 A |
| 0.1 PLC | 0.01 % | 0.01 % | 0.1 % | 0.01 % | 0.01 % | 0.01 % |
| 0.01 PLC | 0.05 % | 0.02 % | 1 % | 0.1 % | 0.05 % | 0.02 % |
| 0.001 PLC | 0.5 % | 0.2 % | 5 % | 1 % | 0.5 % | 0.2 % |

| Data buffers |
|------------------------|
| 100,000 points/channel |

Timer and triggering specification

| | | |
|-------------------------|---|--|
| Timer | Time stamp | TIMER value automatically saved when each measurement is triggered |
| | Trigger timing resolution | 1 μs to 100 ms |
| | Accuracy | ± 50 ppm |
| | Arm/trigger delay | 0 μs to 100,000 s |
| | Arm/trigger interval | 10 μs to 100,000 s |
| | Arm/trigger event | 1 to 100,000 |
| Triggering ¹ | Digital I/O Trigger in to trigger out | ≤ 5 μs |
| | Digital I/O Trigger in to source change | ≤ 5 μs |
| | LXI Trigger in to source change | Min 100 μs , Typical 200 μs , Max Unknown |
| | LXI Trigger in to measurement | Min 100 μs , Typical 200 μs , Max Unknown |
| | Internal event to external LXI trigger output | Min 100 μs , Typical 200 μs , Max unknown |
| | LXI event send/receive latency | Unknown |
| | Min trigger interval | 10 μs |

1. Supplemental characteristics.

Environmental specifications

| Environment | | For use in indoor facilities |
|----------------------|----------|--|
| Operating | | 0 °C to +55 °C, 30 % to 80 % non-condensing |
| Storage | | -30 °C to 70 °C, 10 % to 90 % non-condensing |
| Altitude | | Operating: 0 m to 2000 m, Storage: 0 m to 4600 m |
| Power supply | | 90 V to 264 V, 47 Hz to 63 Hz, 250 VA max |
| Overvoltage category | | II |
| Pollution degree | | 2 |
| EMC | | IEC61326-1/EN61326-1, CISPR11/EN55011 Group 1 Class A, ICES-001 Group 1 Class A, AS/NZS CISPR11 Group 1 Class A, KN61000-6-1, KN11 Group 1 Class A |
| Safety | | IEC61010-1/EN61010-1, CAN/CSA-C22.2 No. 61010-1 |
| Certifications | | CE, cCSAus, RCM, ICES/NMB-001, KC |
| Warm-up | | 1 hour |
| Dimensions | Case | 88 mm H x 213 mm W x 450 mm D |
| | Working | 180 mm H x 260 mm W x 480 mm D (with handle and feet) |
| Weight | Net | 6.0 kg (B2961B), 7.4 kg (B2962B) |
| | Shipping | 9.5 kg (B2961B), 11.0 kg (B2962B) |

| Front panel operation | |
|-----------------------|--|
| Front panel interface | 4.3" TFT color display (480x272, with LED backlight) with keypads and rotary knob |
| View mode | Single view, Dual view and Graph view |
| Hardkeys | Single Trigger and Auto Trigger control, 10-key, Rotary Knob and Cursors, Channel on/off, View, Cancel/Local |
| Softkeys | Function, System and Input Assist Keys |
| Indicators | Channel (measurement) status, System status |

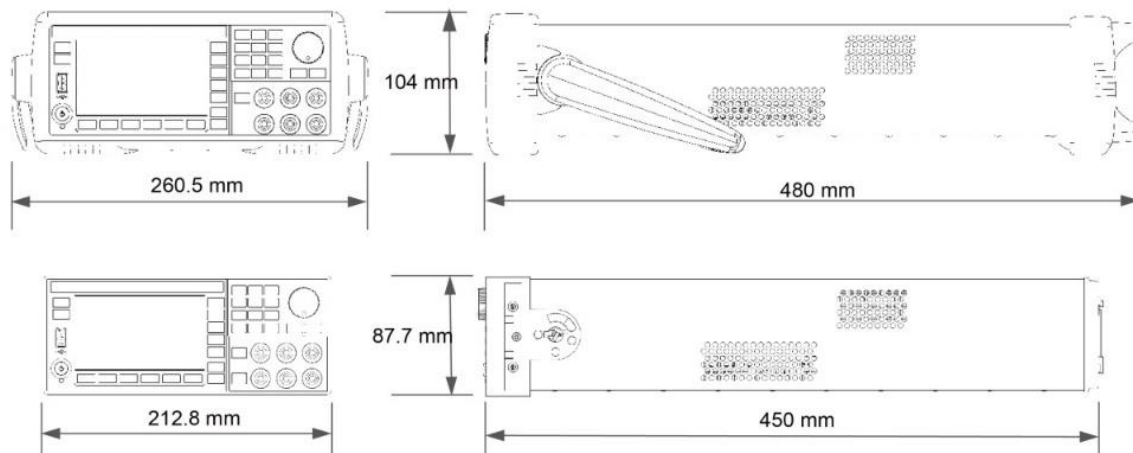

| Input/output connectivity | | |
|---|------------------------------|--|
| GPIB | | IEEE-488.2 |
| Ethernet | | 100BASE-T/10BASE-T |
| USB | | USB 2.0 host controller(front), USB 2.0 device interface (rear) |
| Digital I/O | Connector type | 25-pin female D |
| | Input/output pins | 14 open drain I/O bits |
| | Absolute max input voltage | 5.25 V |
| | Absolute min input voltage | -0.25 V |
| | Logic low max input voltage | 0.8 V |
| | Logic high min input voltage | 2.0 V |
| | Max source current | 1 mA @ $V_{out} = 0$ V |
| | Max sink current | 50 mA @ $V_{out} = 5$ V |
| | 5 V power supply pin | Limited to 500 mA, solid state fuse protected |
| | Safety interlock pin | One active high pin and one active low pin. Activation of both pin enables output voltage > 42 V |
| Max number of simultaneously triggered units (using Digital I/O) ¹ | | 8 |

1. Supplemental characteristics.

| Program, software and drivers | |
|-------------------------------|---|
| Programming | SCPI |
| Program memory | 100 kB (2500 lines typical) |
| LXI compliance | LXI Core Conformance |
| Software available | Quick I/V Measurement Software, Graphical Web Interface, BenchVue |
| Drivers available | IVI-C, IVI-COM drivers, LabVIEW drivers |

| Software prerequisites | | |
|------------------------|-------------------------------------|--|
| Quick IV | Operating system | Windows 8 (32 bit/64 bit), Windows 8.1 (32 bit/64 bit), Windows 10 (32 bit/64 bit) |
| | Supporting language | English (US) |
| | .NET Framework | Microsoft .NET, Framework 4.5.2 |
| | IO Libraries | 17.0 or later |
| | Interfaces | USB, GPIB, LAN |
| BenchVue | Operating system | Windows 10 32-bit and 64-bit (Professional, Enterprise, Education, Home versions) Windows 8 32-bit and 64-bit (Professional, Enterprise, Core) |
| | HDD | Processor: 1 GHz or faster (2 GHz or greater recommended) |
| | | RAM: 1 GB (32-bit) or 2 GB (64-bit) (3 GB or greater recommended) |
| | Display resolution | 1024 x 768 minimum for single instrument view (higher resolutions are recommended for multiple instrument view) |
| Interfaces | USB, GPIB, LAN, RS-232 ¹ | |

1. RS-232 Interface is not available on B2900 family.

Furnished Accessories

Power cable, USB cable, Quick Reference (English)

Ordering Information

| Model number | |
|--------------|--|
| B2961B | 6.5 Digit Low Noise Power Source, 32 W, 210 V, 3 A, 1 ch |
| B2962B | 6.5 Digit Low Noise Power Source, 32 W, 210 V, 3 A, 2 ch |

| Options | |
|---------|---|
| 1A7 | Calibration + Uncertainties + Guardbanding (Not Accredited) |
| A6J | ANSI Z540-1-1994 Calibration |
| UK6 | Commercial Calibration Certificate with Test Data |

| Accessories | |
|-------------|---|
| N1297A | Banana - Triax adapter for 2-wire (non Kelvin) connection |
| N1297B | Banana - Triax adapter for 4-wire (Kelvin) connection |
| N1298A | High current ultra low noise filter, 21 V/500 mA, 10 Ω |
| N1298B | Ultra low noise filter, 42 V/105 mA, 50 Ω |
| N1298C | Low noise filter, 210 V/3 A |
| N1294A-011 | Interlock cable for 16442B (1.5 m) |
| N1294A-012 | Interlock cable for 16442B (3.0 m) |
| N1294A-031 | GPIO-BNC trigger adapter |
| 16494A-001 | Low leakage triax cable (1.5 m) |
| 16494A-002 | Low leakage triax cable (3.0 m) |
| 16494A-003 | Low leakage triax cable (80 cm) |
| 16494A-004 | Low leakage triax cable (40 cm) |
| 16494A-005 | Low leakage triax cable (4.0 m) |
| 1CM124A | Rack mount flange kit |

Learn more at: www.keysight.com

For more information on Keysight Technologies' products, applications or services, please contact your local Keysight office. The complete list is available at: www.keysight.com/find/contactus

